

# STROMER

POWER

## Comprehensive Specification Sheet

Low-Voltage AC Alternator  
Electrical and Mechanical Data



### STRO-350K

325 kVA Prime / 364 kVA Standby  
Three Phase / 50Hz / 4 pole

## WORLD CLASS ALTERNATORS

StromerPower is a global leader for quality alternators from 10kVA to 1100kVA  
We provide alternators for generator set manufacturers and power producers worldwide

Every day, our products help secure access to power for thousands of people

We offer solutions for all standby and prime applications, from industrial outposts and mines to busy commercial zones and even residential neighborhoods

StromerPower alternators are available globally through a network of trusted distributors who adhere to our stringent quality controls and share our commitment to quality, reliability and trust



## STANDARDS QUALITY AND PRECISION

StromerPower alternators meet all key international standards and regulations  
Our alternators comply with the following major domestic and international standards and regulations  
**GB755, BS5000, IEC60034, VDE0530, CSAC22.2 100, NEMA MG-1.22**  
Designed, manufactured and marketed in an **ISO 9001** quality assurance environment  
our alternators can be integrated in CE-marked generator set

## ABOUT THE FACTORY BUILT ON LEGACY

Our factory has been providing world-class alternators and power generation solutions since 1955 with the vision of becoming a leading manufacturer of world-class alternator products.

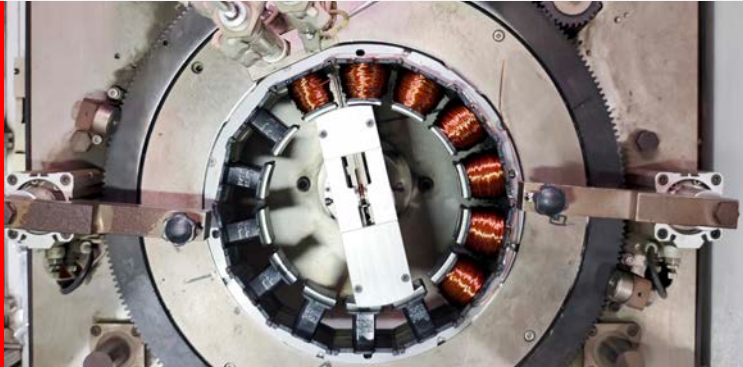

**FACTORY  
STATISTICS**

**+60**  
years of experience

**+30,000**  
square meter workshop

**ISO 9001**  
quality rated

# STRO-350K

Three Phase / 325 kVA Prime / 364 kVA Standby / 50Hz / 4 pole

## Dimensions

Unpacked				Packed			
Length	Width	Height	Net Weight	Length	Width	Height	Gross Weight
mm			kg	mm			kg
980	646	818	757	1100	770	1070	835

## Specifications Overview

Single Phase / 50Hz / 400V / PF = 1			
Continuous 40 °C		Standby 40 °C	
kw	kVA	kw	kVA
260	325	291	364

Rated Frequency	Voltage	Voltage Regulation	Voltage Regulation Change	Phase Change Rate	Power Factor
Hz	v	v	% UN	%	
50	400	+/- 1%	< +/- 10	+/- 1	0.8

Insulation Class	Type	Phase and Connection	
H	IM B35	Single Phase	Series Star

AVR Model	Stator	Rotor
AS440	2/3 Pitch	Single Bearing



## SAE Rating

Model	LB	LC	Xg	kg
	SAE			
STRO-350K	936	383	433	766

## Adapter

SAE	BX	AM	AR - øAS	AH
	mm			
#1/14"	466.725	438.15	8 - ø14	25.4

## Flange

SAE	P	N	M	R - øS	W	D	a°
	mm						
#1/14"	646	511.175	530.225	12 - ø12	6	232	15

# STRO-350K

Three Phase / 325 kVA Prime / 364 kVA Standby / 50Hz / 4 pole

## Mechanical Construction

- StromerPower enclosures are IP23
- All rotors are dynamically balanced in strict accordance with the requirements of the ISO1940 standard
- Robust flanges and shields
- The large junction box makes wiring and adjustment of the AVR easier
- Space for current transformers or other optional modules to be installed
- Compact design and sturdy assembly to withstand generator vibrations
- All our alternators use long-term sealed bearings
- Steel base

## Excitation System Regulations

- **Parallel Use:** When the appropriate modules (AVR, current transformer and control equipment) are installed, all 2-pole alternators can be used in parallel
- **Bearing Capacity:** NEMA specifications
- **Waveform:** According to the IEC standard, the total harmonic distortion rate is less than 5% under no-load or non-linear load. The telephone interference factor (TIF) is less than 50 in accordance with NEMA specifications
- **Frequency:** To be used at a frequency of 50Hz (standard windings) (No. B31, B32)
- **Power Factor:** The alternator is designed for loads with a power factor of 1

## Single-Bearing Outline Schematic

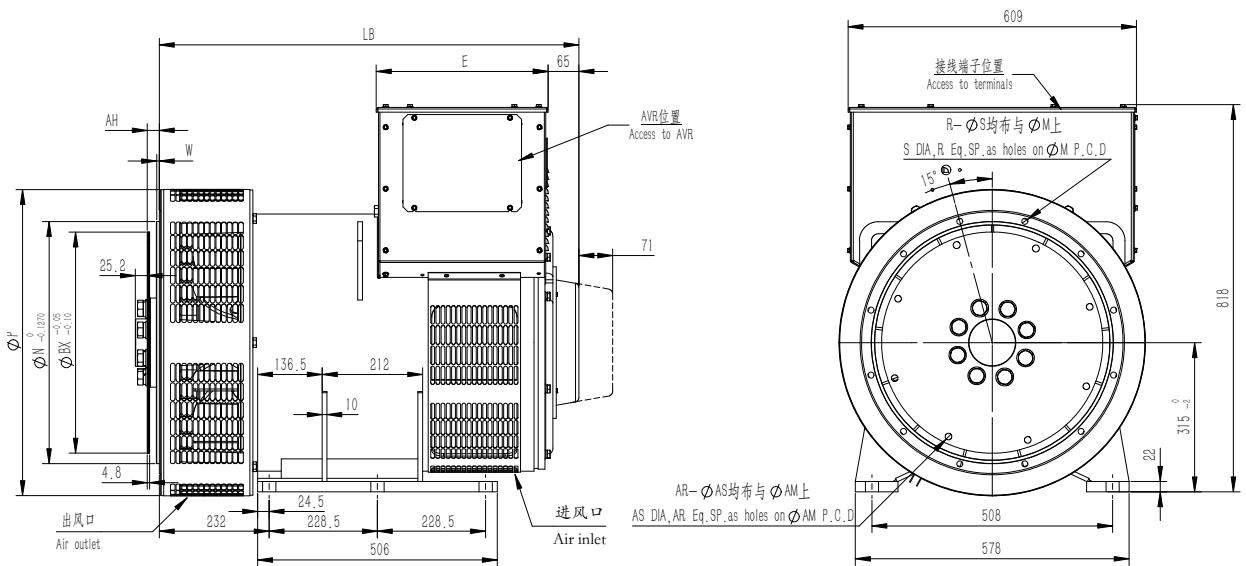

Fan		Main Rotor		Excitation Rotor		Shaft		Total	
Weight (kg)	J(kgm <sup>2</sup> )	Weight (kg)	J(kgm <sup>2</sup> )	Weight (kg)	J(kgm <sup>2</sup> )	Weight (kg)	J(kgm <sup>2</sup> )	Weight (kg)	J(kgm <sup>2</sup> )
12.4	0.3291	194.6	2.765	18.3	0.1516	59.2	0.0778	284.5	3.3235

SAE	5	Shafts Coupling Flex Plate		
	D	L	Weight (kg)	J(kgm <sup>2</sup> )
#1/14"	232	936	6.26	0.1754

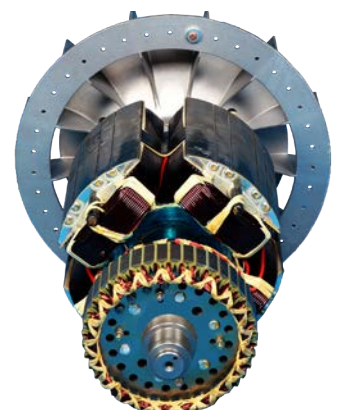

# STROMER

POWER

Stromer Power Low-Voltage AC Alternator -STRO-350K

© StromerPower  
The information contained in this brochure is for guidance only and does not form part of any contract. The accuracy cannot be guaranteed as StromerPower have an ongoing process of development and reserve the right to change the specification of their products without notice.